

J-TOWbiz1-T

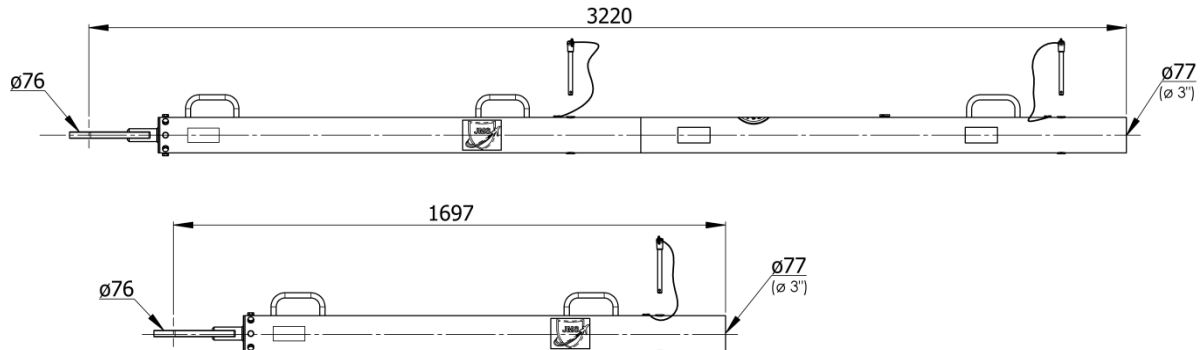

Standard features:

- Aluminium tow bar tube, easy collapsible by means of quick-release-pins
- Quick-release-pin for easy towhead attachment
- Carrying-handles for safe operation/handling of the unit
- Skydrol resistant paint
- Standard colour yellow RAL 1007
- Compatible to J-TOWheads of JMS D-Series, but also to other universal business jet towheads using a $\varnothing 83\text{mm}$ / $\varnothing 3\ 1/4''$ tube lock system

Net weight: (for towbar without towhead)

- 26 kg / 57 lbs

Documentation:

- Technical manual incl. illustrated spare parts list
- COC Certificate of Conformity
- CE Declaration of Conformity (if applicable)

Options (at extra charges):

- Transportation Box – P/N J-TOWbiz1-TB made of Multiplex panel V100
 Paint colour light grey RAL 7035
 Equipped with support blocks for the demounted tow bar pieces and towhead.
 Forklift attachments.
 Weight: approx. 25kg / 55 lbs
- Revolving tow eye
 ➔ Option DP
- Revolving tow eye with shock absorber
 ➔ Option DA
- Customized color for towbar tube i.a.w. RAL coding scheme
 ➔ Option D-RAL

Transportation dimensions:

(without Transportation Box P/N J-TOWbiz1-TB)

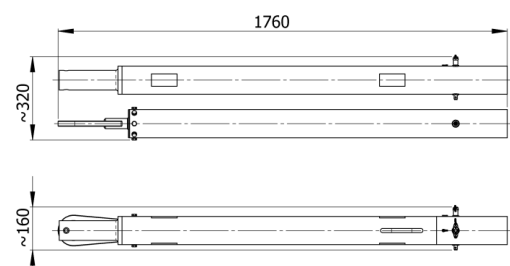

Shipping information incl. packing:

Approx. Weight	Approx. shipping Dims l x w x h	Approx. Volume
[kg]	[mm]	[m ³]
50	1800 x 400 x 300	0,21
[lbs]	[inch]	[ft ³]
110	71 x 16 x 12	7,6