

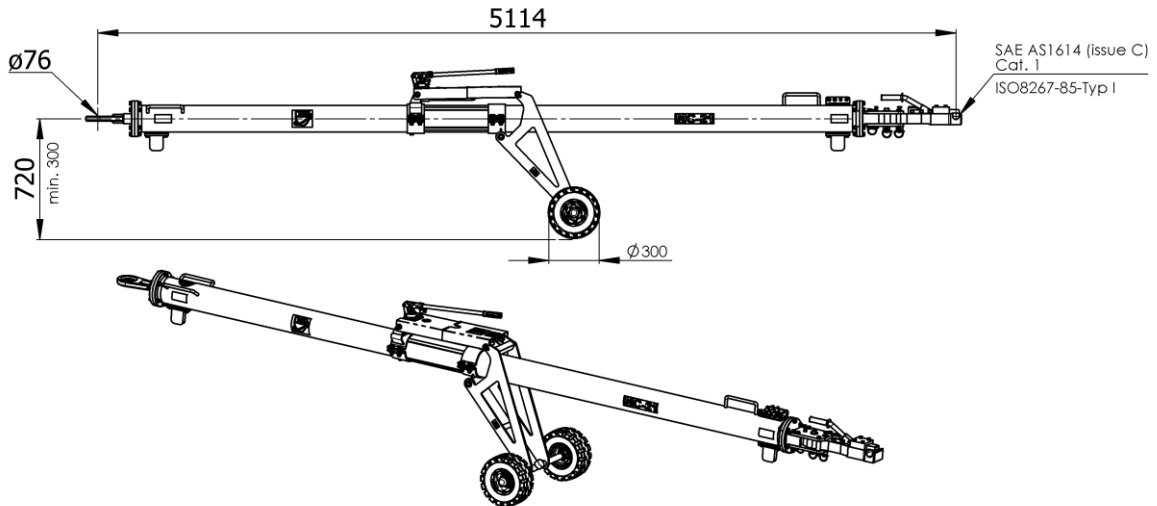

J-TOW21



Standard features:

- 1xPush/Pull and 1xTorque shear pin mounted, replaceable without using tools (add. as spare parts incl.: 2xPush/Pull and 2xTorque shear pins)
- 1xRetaining pin, replaceable without using tools
- FOD-Protection device:
No shear pin debris will be lost in case of shear pin fracture!
- Automatic locking mechanism
- Air-inflated tires
- Hydraulically height adjustable undercarriage
- Steel tube
- Skydrol resistant paint
- Standard colors: yellow RAL 1007 (tube), black RAL 9004 (undercarriage)

Net weight:

- 235 kg / 518 lbs

Aircraft application:

- UAC/IRKUT MC-21 -200/ -300
* also A320family / B737 all types

Options (at extra charges):

- Puncture-proof (full rubber) tires
→ Option R3
- Revolving tow head $\pm 10^\circ$
→ Option BD
- Revolving tow eye
→ Option BP
- Revolving tow eye with shock absorber
→ Option BA
- Customized color for towbar tube i.a.w. RAL coding scheme
→ Option B-RAL

Documentation:

- Technical manual incl. illustrated spare parts list
- COC Certificate of Conformity
- CE Declaration of Conformity (if applicable)

Shear pins / Retaining pin:

- 20-01040-0020-022 "BA" Push/Pull
- 20-01040-0020-025 "BB" Torque
- 20-01040-0020-021 "BA-FB" Retaining pin

Shipping dimensions incl. packaging:

Approx. Weight	Approx. shipping Dims l x w x h	Approx. Volume
[kg]	[mm]	[m ³]
285	5320 x 1000 x 720	3,8
[lbs]	[inch]	[ft ³]
628	209 x 39 x 28	134.2

* Optional usage with A320/B737:

- No $\phi 400$ tires possible due to low tow fitting height of B737
- Separate shear pins necessary