



J-POD35SA01

Standard features

- Tripod steel frame, welded structure incl. bubble-level, forklift-tray and tow-bar (ø76mm/3" eye)
- Hydraulic lift cylinder (single-stage) with corrosion protected piston, hard-chrome plated cylinder bore and **manual safety lock-nut** (preventing cylinder from descending in case of hydraulic pressure drop/failure)
- Interchangeable spherical jacking adapters
- Aluminum access ladder with handrails and working platform with back-fall protection bar
- Manually height adjustable foot plates (to be operated in upright/standing position)
- Spring-loaded heavy-duty castors with directional locks
- Steel hydraulic tank with all required valves for manual jack operation incl. oil level (sight glass), pressure filter and active-charcoal tank aeration filter
- Hydraulic pressure/load gauge ø63mm, class 1.6 (dial in [bar])
- Twin hand-pump unit for low-pressure (LP) and high-pressure (HP) operation
- Electrically driven hydraulic pump; connection parameters: 3-phase AC 380-420V, 50/60Hz
- Electrical cabinet with main switch and power-supply cable, length 10m incl. 16A CEKON plug

Optional features

- Air-hydraulic drive
- Hydraulic height-adjustable heavy-duty castors with directional locks
- Hydraulic pressure/load gauge ø160mm, class 1.0 calibrated (dial in [bar/psi, kN/US short tons])
- Proof-load test fixture with electrical load cell (J-TF series)
- Further options on request

Finish

- Main tripod structure incl. hydraulic tank painted with 2K-PU SKYDROL-resistant paint
- Standard color RAL 1007 (daffodil yellow); other RAL colors upon request
- All non-painted components galvanized (zinc-plated) for corrosion protection

Documentation

- CE-compliant operation and maintenance manual incl. illustrated spare parts list
- Certificates: Factory proof-load test, CoC (Certificate of Compliance), CE Declaration of Conformity

JMS AG
Rainer-Haungs-Strasse 42
77933 Lahr/Germany

Phone: +49 (7821) 9 94 69 – 0
Fax: +49 (7821) 9 94 69 – 100



Internet: www.jms.aero
E-Mail: sales@jms.aero

TDS_J-POD35SA01_R03.docx

Page 2 of 3

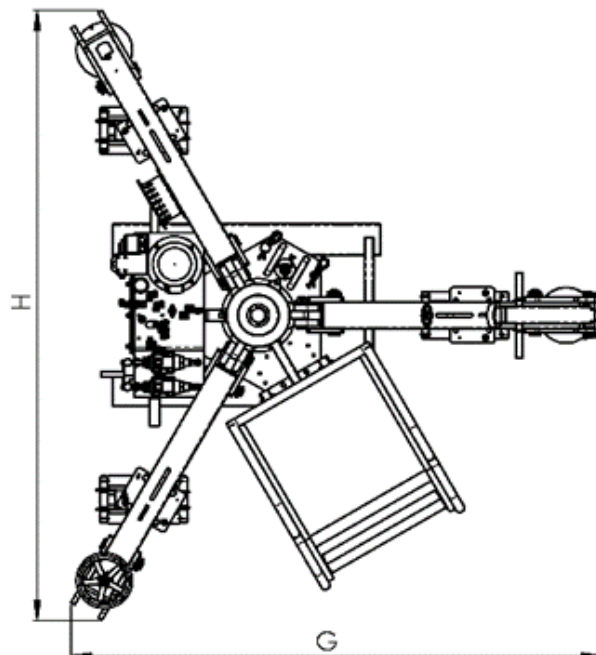
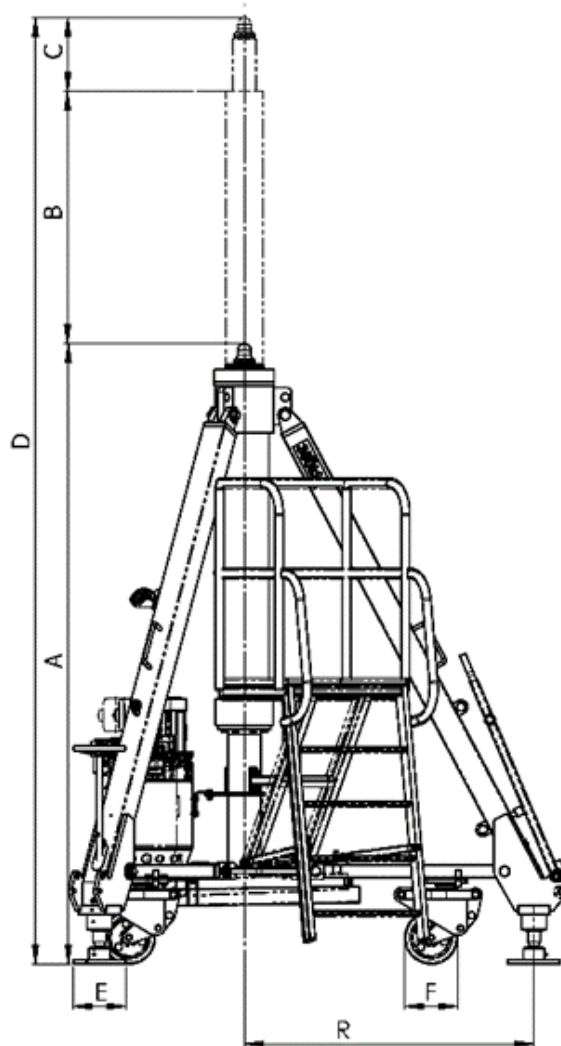

JMS AG

Rainer-Haungs-Strasse 42
77933 Lahr/Germany

Phone: +49 (7821) 9 94 69 – 0
Fax: +49 (7821) 9 94 69 – 100



Internet: www.jms.aero
E-Mail: sales@jms.aero

TDS_J-POD35SA01_R03.docx

Page 3 of 3

Dimensions

- Lifting capacity (SWL) : 35 t (38,6 US short tons)
- Minimum height (A) : 2950 mm (116,1 inches)
- Hydraulic lift (B) : 1300 mm (51,2 inches)
- Screw extension (C) : 250 mm (9,8 inches)
- Maximum height (D) : 4500 mm (177,2 inches)
- Pitch circle radius (R) : 1380 mm (54,3 inches)
- Foot plate diameter (E)..... : 250 mm (9,8 inches)
- Ground pressure at SWL..... : 2,4 N/mm² (348 psi)
- Castor diameter (F) : 250 mm (9,8 inches)
- Leg width "short" side (G) : 2380 mm (93,7 inches)
- Leg width "long" side (H) : 2747 mm (108,1 inches)
- Approx. net operating weight..... : 1450 kg (3197 lbs)
- Jacking adapter, size..... : R1,25" convex
- Operating temperature : -20°C ≤ T ≤ 60°C (-4°F ≤ T ≤ 140°F)
- Hydraulic oil..... : ESSO Univis HVI13

Transportation

- Standard transport method..... : knocked-down on wooden pallet (ISPM-15) with folded legs
- Length overall..... : 3600 mm (141,7 inches)
- Width overall : 2000 mm (78,7 inches)
- Height overall : 1600 mm (63,0 inches)
- Approx. gross weight..... : 1600 kg (3527 lbs)

Aircraft applications

- A318/ACJ318 (Wing)
- A319ceo/A319neo/ACJ319 (Wing)
- A320ceo/A320neo/ACJ320 (Wing)
- A321ceo/A321neo/LR (Wing)
- L-100/C-130 HERCULES (Wing)
- Further applications upon request